

Kołek gwintowany

Threaded Stud

Gewindebolzen

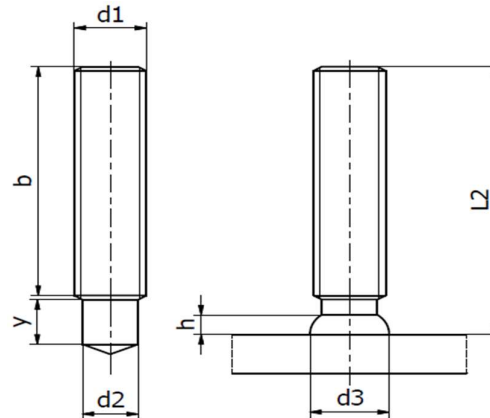

Materiał, Material, Werkstoff:
4.8, A2-50,
A4-50, A5-50

Powłoki:
-galwanicznie ocynkowana
-galw. ocynkow. i chromianowana
-galwanicznie miedziowana
-galwanicznie niklowana

Coatings:
-zinc plated
-zinc plated & chromating
-copper plated
-nickel plated

Beschichtungen:
-galvanisch verzinkt
-galvanisch verzinkt und chromatiert
-galvanisch verkupfert
-galvanisch vernickelt

Materiał, Material, Werkstoff: 4.8

Waga (kg/100)			Pierścień ceram.				Uchwyt kołka	Uchwyt pierśc. ceram.	Podstawa pistoletu	
d ₁	L ₂	Weight	d ₂	d ₃	h	Y+2P/b	Ferrule Type	Chuck	Ferrule Grip	Foot Assembly
	(mm)	Gewicht	(mm)	(mm)	(mm)	(mm)	Keramikring	Bolzenhalter	Keramikringhalter	Fußplatte
M6	15	0,262	5,35	8,5	3,5	9/-	UF6/PF6	25-35-00	65-07-00	NS20:36-01-00 NS40:36-06-11 dla wszystkich długości
M6	20	0,349								
M6	25	0,436								
M6	30	0,523								
M6	35	0,610								
M6	40	0,697								
M6	45	0,784								
M6	50	0,871								
M6	55	0,958								
M6	60	1,045								
M8	20	0,610	7,19	10,0	3,5	9/-	PF8	25-08-00	65-08-00	NS20:36-01-00 NS40:36-06-11 dla wszystkich długości
M8	25	0,770								
M8	30	0,930								
M8	35	1,090								
M8	40	1,250								
M8	45	1,410								
M8	50	1,570								
M8	55	1,730								
M8	60	1,890								
M8	70	2,210								
M8	80	2,530								
M8	90	2,850								
M8	100	3,170								
M10	20	1,017	9,03	12,5	4,0	9,5/-	PF10	25-09-00	65-09-00	NS20:36-01-00 NS40:36-06-11 dla wszystkich długości
M10	25	1,318								
M10	30	1,565								
M10	35	1,811								
M10	40	2,058								

