

Forma A

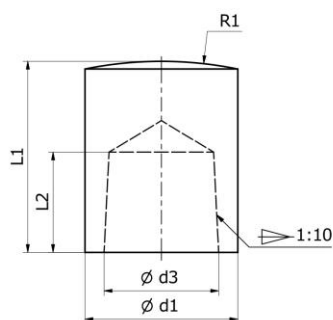

Forma B

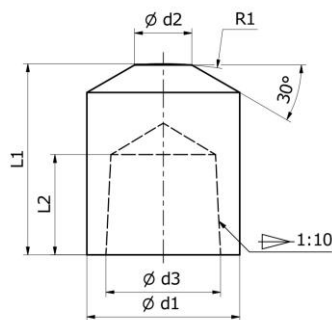

Forma C

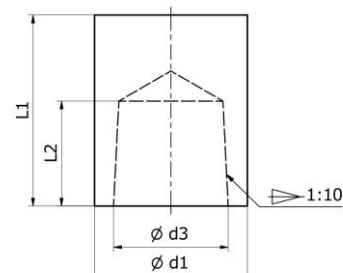

Forma D

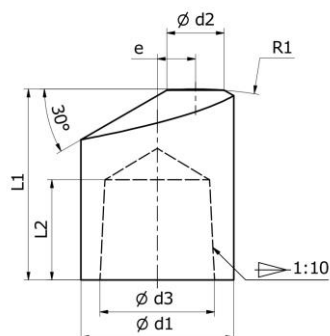

Forma E

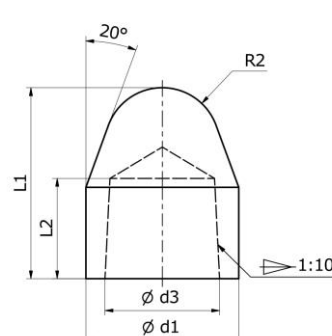

Forma F

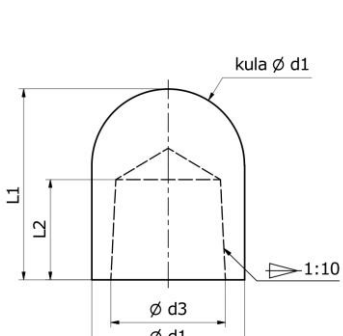

Forma G

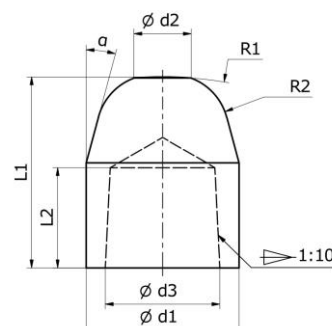

Sposób zamawiania: Forma + d1 (np. F16)

Materiał: CuCr1Zr Powerode Cr+®

Twardość: >160HB

Tolerancja: ISO 2768-m

d1 h11	d2	d3	L1	L2 +0,5	e	R1	R2	α	Siła nacisku Pressure force F max [kN]
13	5	10	18	8	3	32	5	-	2,5
16	6	12	20	10,5	4	40	6	15°	4
20	8	15	22	11,5	5	50	8	22,5°	6,3